



LEADER IN QUALITY ATTACHMENTS





LEADER IN QUALITY ATTACHMENTS

ABOUT PSM CORPORATION

Founded over 20 years ago by President Walt Pisco, PSM Corporation prides itself on where it has been and the direction it is headed.

Starting out in hydraulic installations, Walt Pisco and a small team of PSM employees built the company from the ground up. By trial and error, PSM has found the perfect combination of strength, reliability, and versatility in all of its certified attachments.

PSM Corporation now employs over 100 persons throughout the country who are committed to product and customer support. Already selling thousands of attachments annually, PSM Corporation will be extending its production by opening up a new plant with twice the capacity PSM has always been devoted to.

PSM Corporation, "Leader in Quality Attachments." Keeping up with market needs, and as the market changes, so will PSM.

TO OUR VALUED CUSTOMER:

We would like to welcome you to the growing number of satisfied people utilizing PSM Corporation products.

Log Style Thumbs, Heavy Duty Buckets, Continuous Rotating Grapples, and Free Hanging Clamshells are just a few items that we manufacture for the hydraulic excavator to maximize performance in a variety of applications. We specialize in attachments used in construction, logging, road building, demolition, recycling, waste management, and mining to better serve the heavy equipment community.

We are committed to providing excellent after-sale product support in parts and in service. From a parts call to service in the field, PSM is here to help your company.

Thank you for your support of our products and our company. If you have any questions, please feel free to obtain more information at our website or call (800) 373-3514.





EXCAVATOR THUMB & BUCKETS



SERIES II SEVERE APPLICATION THUMB & BUCKET

A PSM Alaskan road builder, or dominator bucket, provides the ultimate in abrasion resistance while retaining field serviceability. This product will stand up to the most severe applications where the competitor cannot.

The PSM Series II design is a product for a new generation of excavator buckets and thumbs designed for strength, durability, and capacity. PSM products are highly versatile and compatible with any major make and model of machine. Make the quality decision and purchase a quality product. PSM, handling all of your attachment needs.

PSM Corporation presents its innovative thumb and bucket. Designed for the toughest of applications, a PSM thumb and bucket will give you all the versatility you will need to dig, hold, load, unload, demolish, and place. The dual progressive links in the Series II design allow greater range of travel, even gripping power, and eliminates any chance of a thumb body twist. This proven design will provide you thousands of hours of reliable service and is backed by a product support team that is second to none.



SERIES II HEAVY-DUTY THUMB & BUCKET



SERIES II HEAVY-DUTY PIN GRABBER THUMB & BUCKET



HYDRAULIC BUCKET CLAMP (THUMB)

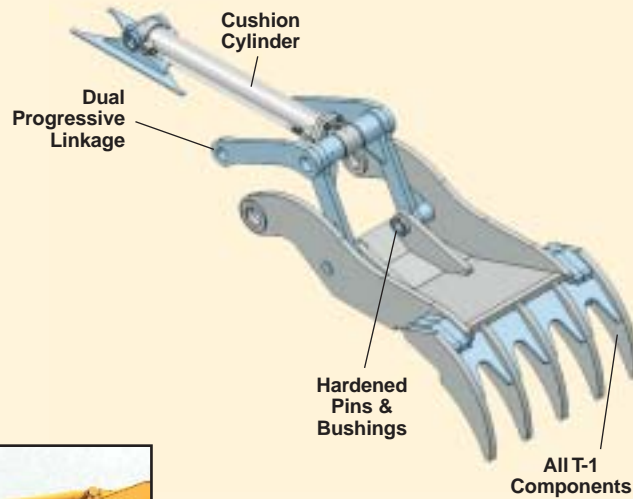

Versatility

The ability to clamp, to hold, to load, unload and place. This all becomes possible with the addition of a PSM Hydraulic Bucket Clamp (Thumb) to your hydraulic excavator. With the addition of a thumb, your excavator becomes a multi-purpose tool. Not only will you use it for digging, you will use it for clearing land, demolition, placing pipe, loading and unloading trucks, handling rocks and logs, feeding crushers and grinders, sorting material, piling brush and for using an "H" beam to grade asphalt.



SERIES II PROFILE FOR PIN GRABBER Q.C. UTILIZE THUMB WITH MULTIPLE ATTACHMENTS



SERIES II PROFILE AGGRESSIVE UNIVERSAL PROFILE, LINKAGE OR NO-LINK DESIGNS



NO-LINK LIGHTER WEIGHT, LIMITED TRAVEL, NON-HYDRAULIC AVAILABLE



LOG PROFILE AGGRESSIVE RADIUS CRADLES ROCK, LOG, DEMOLITION DEBRIS

Integrity by Design

The proven design of the PSM "Thumb" will provide thousands of hours of reliable service. Every thumb is engineered to fully integrate with each model of excavator and bucket for maximum travel and compact storage. PSM utilizes high strength T-1 steel for a strong, light thumb, a 6-10 head gland cylinder with decelerating hydraulic cushion, and assembles the fully lined bored thumb with heat treated bushings and induction hardened pins. The wide stance of the double link, double pin linkage design provides protection from torsion damage due to uneven loading of the thumb.

PSM Thumbs are available in Series II, Straight and Log Profile in both Link and No-Link designs.



EXCAVATOR BUCKETS

Buckets are available in a variety of styles, widths, and capacities. PSM will design buckets for excavators weighing between 15,000 lbs. and 250,000 lbs.



SEVERE APPLICATION

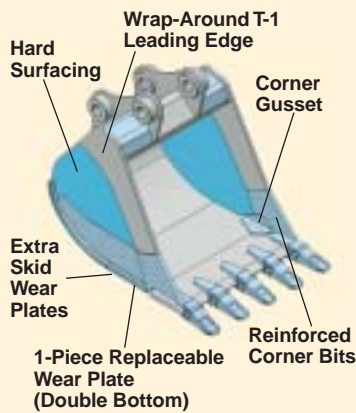

Bucket Features

- Full T-1 Double Bottom Standard
- Heavy-Duty T-1 Leading Edge
- Quick Coupler or Standard Pin-On Lugging
- Choice of Teeth
- T-1 Cutting Edge
- Lifting Eye
- T-1 Side Plates

Bucket Varieties

- Severe Application Bucket
- Heavy-Duty Bucket
- Ditching Bucket
- Multi-Shank Rock Ripper Bucket
- Clean-Up Application Bucket
- Clamp Bucket Combination
- Pin Grabber Special



CLEAN-UP

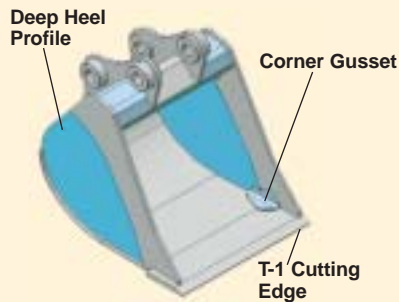

DITCHING

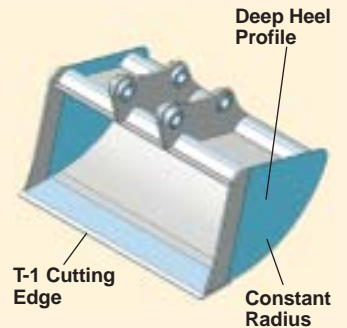

HEAVY DUTY

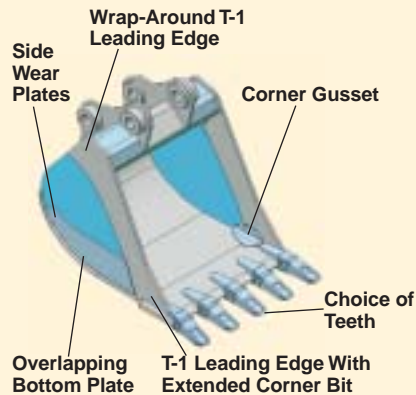

MULTI-SHANK ROCK RIPPER

Three-Part Frogg (more strength, shorter tip radius)

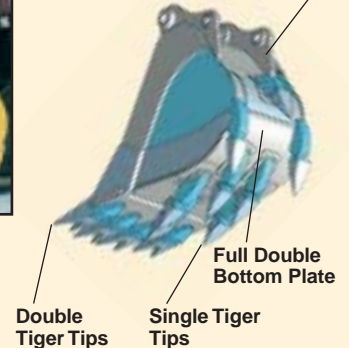



SERIES II CLAMP/BUCKET COMBO

Patent Pending

Versatility • Economy • Performance • Safety



- The total solution for easy, safe removal of a thumb and bucket as a single unit
- Thumb and bucket rotate on a common axis for constant grip throughout arc
- Available in progressive link or no link thumb designs
- Reduces weight
- Fits all coupling systems
- Interchangeable between excavators of similar weight for maximum utilization



PIN-ON CLAMP/BUCKET COMBO



WEDGE-STYLE CLAMP/BUCKET COMBO

The versatility of a thumb without the limitations.



GRAPPLES & CLAMSHELLS

PSM has created and proven the perfect design for all of your Articulating and Free-Hanging Clamshell and Grapple needs. Built with T-1 steel construction, geared slew ring bearings, with hardened bushings and pins, a PSM clamshell or grapple is sure to meet all of your construction needs.



ARTICULATING GRAPPLE

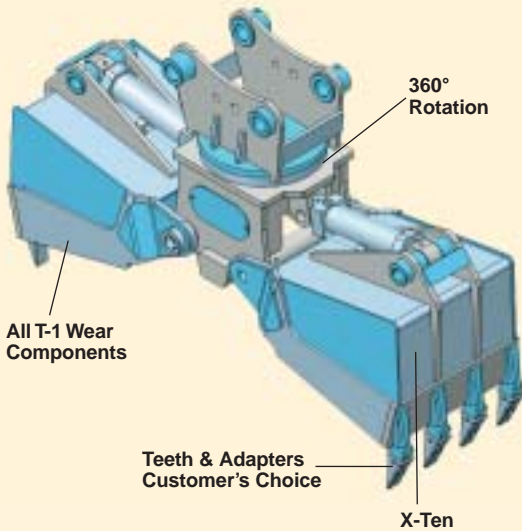

The success of a PSM clamshell and grapple revolves around the versatility the machine offers. 360° rotation is provided by a high torque hydraulic motor running in unison with a high pressure swivel union. Whether you are loading and unloading, cleaning up, placing rock, or doing demolition work, your PSM clamshell or grapple will exceed all expectations.

Built for compatibility, PSM offers our customers the option of adding any specialty jaws or rakes available to interchange with a fitting bucket. Also available is a choice of replaceable teeth or cutting edge.

PSM, handling all of your attachment needs.



ARTICULATING CLAMSHELL



FREE-HANGING CLAMSHELL



ARTICULATING CLAMSHELL

**Construction • Demolition • Rockeries • Logging • Scrap
Solid Waste • Pipeline • Riprap • Piling**

PSM COMPACTION WHEELS

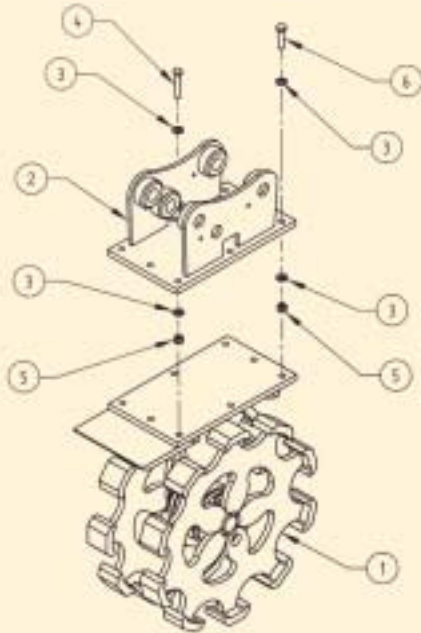

BOLT-ON ADAPTER WELDMENTS

ITEM	DESCRIPTION
1	BASIC COMPACTION WHEEL ASSEMBLY
2	MOUNTING LUG WELDMENT
3	WASHER HARDENED
4	BOLT
5	LOCK NUT
6	BOLT

PSM Compaction Wheels featuring octagonal feet for efficient, fast compaction in both cohesive and non-cohesive soil conditions. The self-cleaning design and standard strike-off plates assure maximum penetration and mixing for maximum performance. The self-aligning roller bearings

with top mount lubrication assure long trouble-free life. Compaction wheels keep workers out of the trench while achieving required soil densities in a fraction of time. Fabricated of high strength, low carbon steel, the PSM Compaction Wheel is designed for the most severe conditions.

SALES SUPPORT

PSM offers Field Sales Support, In-House Sales Support, and a full-time order desk.

Customers can call our toll-free number and be assured of a quick response to their needs. For basic orders, customers can call or fax our order desk. Fax (206) 486-0803. For special needs or questions, ask for one of our In-House Sales Representatives or meet with a Field Sales Representative.

SERVICE

PSM backs up its attachment lines with complete parts and service support, hydraulic packages, components, and installations. All products, accessories and workmanship are backed by a solid warranty.

DEPENDABILITY

Efficiency, quality, and innovativeness are important in our Production Department's ability to meet demands for short lead times from date-of-order to receipt-of-product.

PSM maintains a stock of inventory to meet many immediate and emergency delivery requirements.

The Engineering Department can custom design attachments to meet individual needs or specialized applications.

PSM is managed and staffed by a team of dedicated people. They care about the products they manufacture and the customers they serve.



Pacific Services & Manufacturing, Inc.

**8502 Maltby Road
Woodinville, WA 98072**

Phone: (425) 486-1232, (800) 373-3514

Fax (425) 486-0803

Web Site: www.psmcorp.com

E-Mail: info@psmcorp.com